

2013 Ford Explorer Limited

SYSTEM WIRING DIAGRAMS

Fig. 82: Power Door Locks Circuit, W/ Intelligent Access (1 of 2)

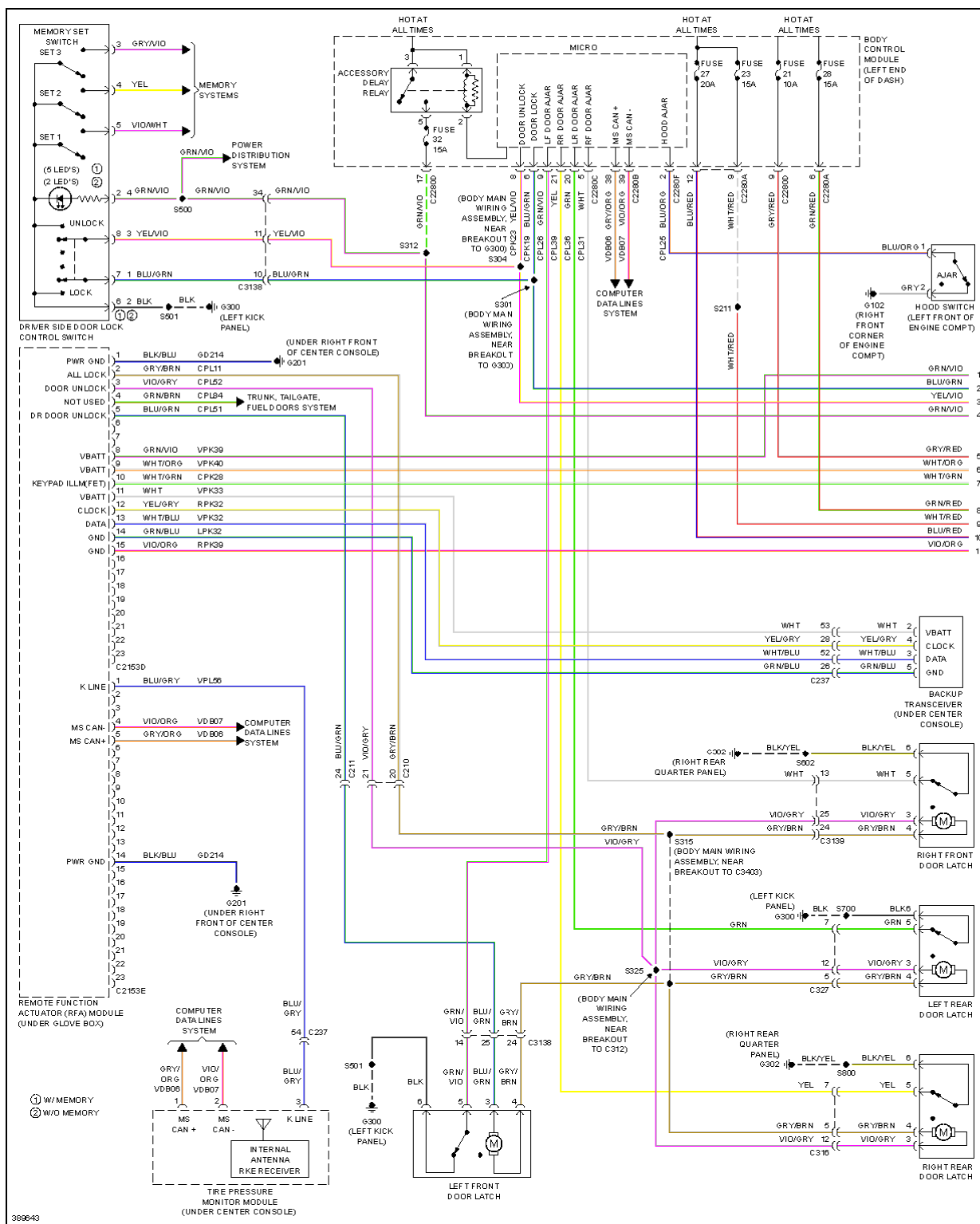

2013 Ford Explorer Limited

SYSTEM WIRING DIAGRAMS

Fig. 83: Power Door Locks Circuit, W/ Intelligent Access (2 of 2)

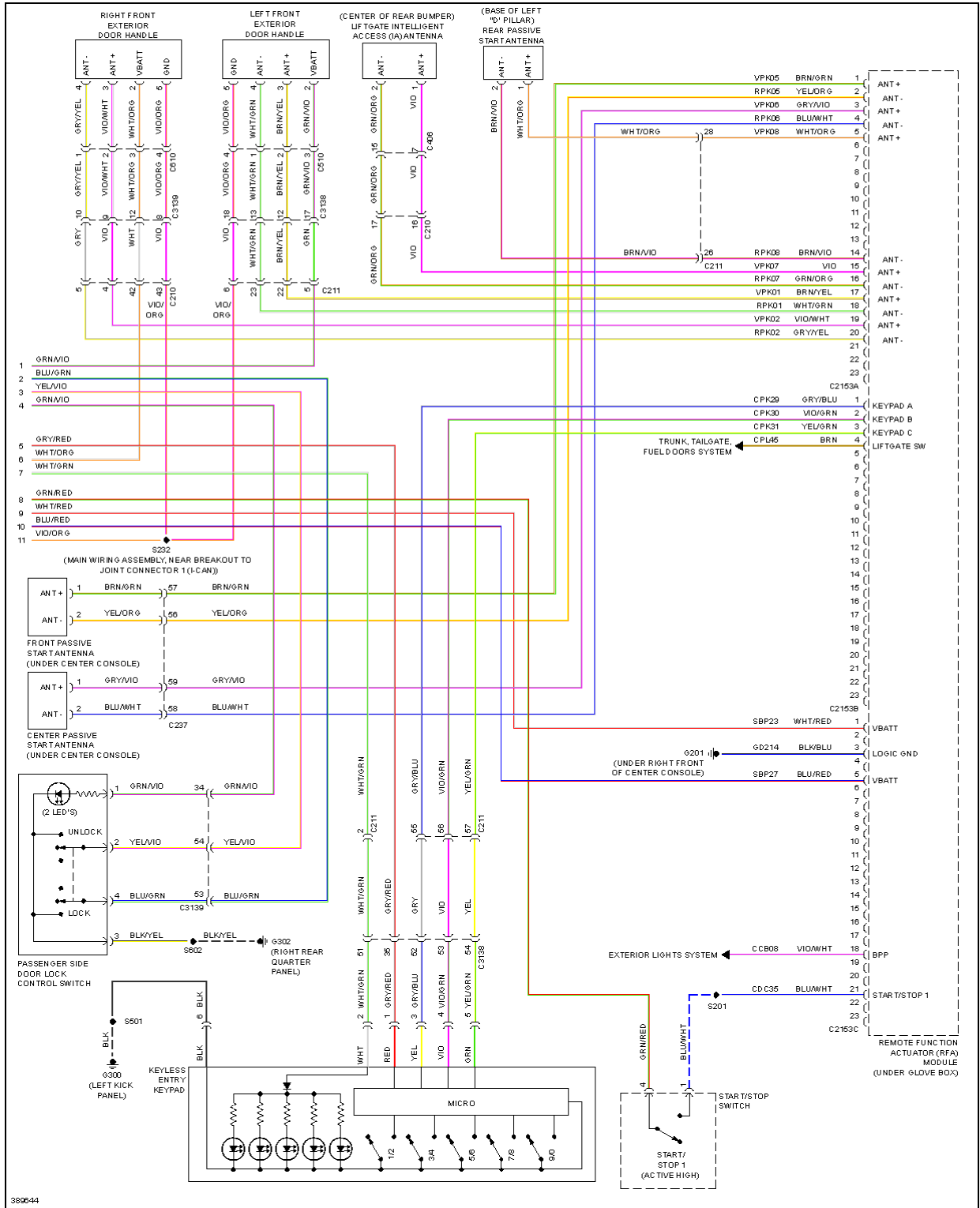

2013 Ford Explorer Limited

SYSTEM WIRING DIAGRAMS

Fig. 84: Power Door Locks Circuit, W/O Intelligent Access (1 of 2)

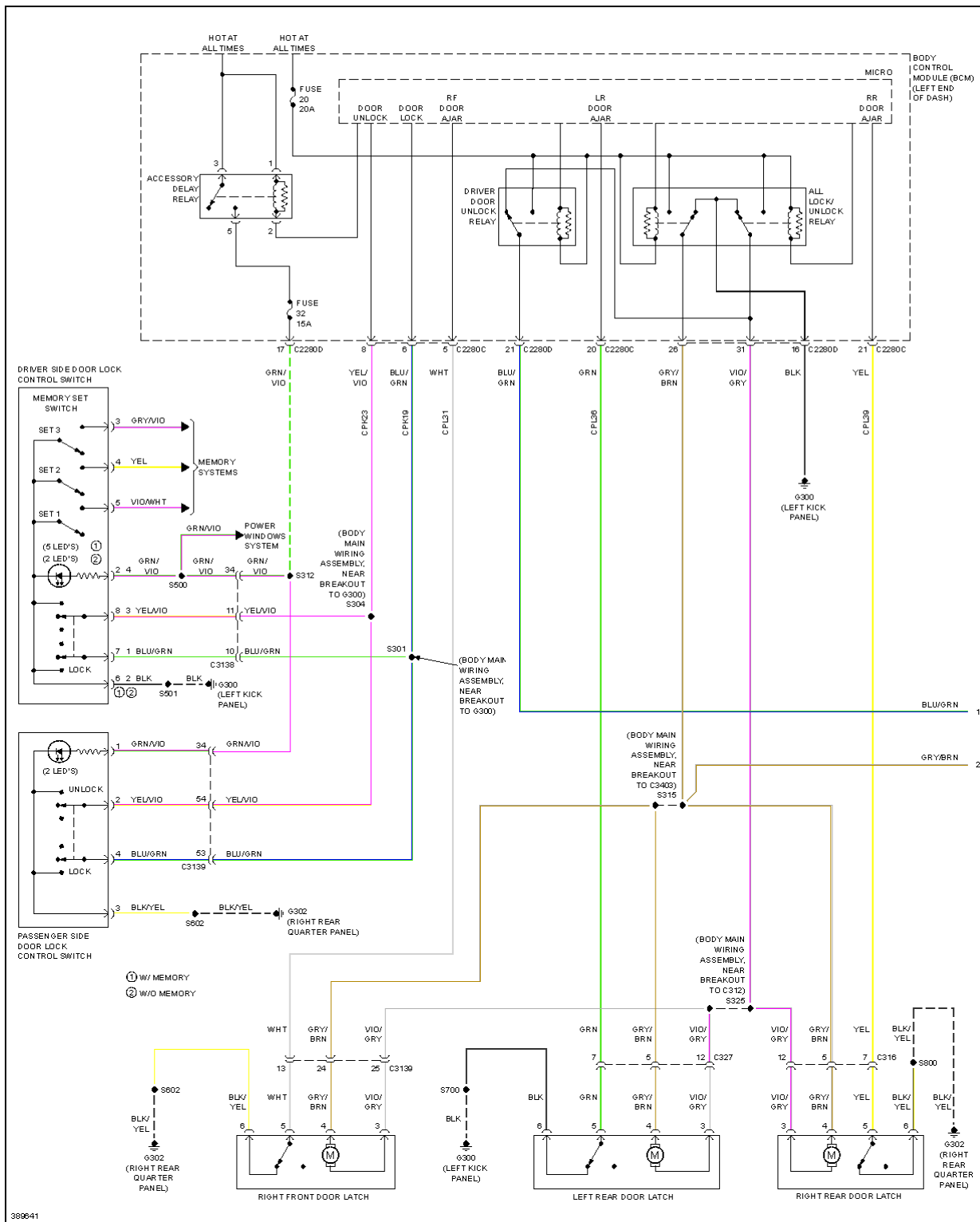

2013 Ford Explorer Limited

SYSTEM WIRING DIAGRAMS

Fig. 85: Power Door Locks Circuit, W/O Intelligent Access (2 of 2)

